



# INSTALLATION

## AIRMASTER™ PERFORMANCE WINDSHIELD 1383

**FITS: ALL '01-UP GL1800 MODELS**

*Note: Vent not included, requires OEM vent for proper installation*

### PARTS INCLUDED

- 1 Performance Windscreen
- 1 Hardware Kit Including:
  - 2 Flat Washers
  - 1 2x1" Adhesive Backed Foam Pad
- 1 Installation Instructions

*Please read and understand entire instructions before starting installation.*

### THANK YOU FOR CHOOSING KÜRYAKYN!

**IN ORDER TO PROTECT YOU AND OTHERS FROM POSSIBLE INJURY AND/OR PROPERTY DAMAGE OR LOSS, PLEASE PAY CLOSE ATTENTION TO ALL INSTRUCTIONS, WARNINGS, CAUTIONS AND ATTENTION NOTES REGARDING THE USE AND CARE OF THIS PRODUCT.**

**WARNING!** THIS INDICATION ALERTS YOU TO THE FACT THAT IGNORING THE CONTENTS DESCRIBED HEREIN CAN RESULT IN POTENTIAL DEATH OR SERIOUS INJURY.

**CAUTION!** This indication alerts you to the fact that ignoring the contents described herein can result in potential injury or material damage.

**ATTENTION!** This indication alerts you to the fact that ignoring the contents described herein may negatively affect product performance and functionality.

### TOOLS SUGGESTED

Set of hex wrenches, Phillips screwdriver.

**STRICTLY OBSERVE THE FOLLOWING GUIDELINES IN ORDER TO USE THE PRODUCT PROPERLY AND AVOID POTENTIALLY DANGEROUS ACCIDENTS.**

### PROCEDURE

**STEP 1** Read and understand all steps in the instructions before starting the installation. Park the motorcycle on a hard, level surface and turn off the ignition.

**STEP 2** Pull the rubber boot back from the fairing at the base of the mirrors.

**STEP 3** Referring to FIG. 1, remove the bolts, washers and mounts that secure the windscreen garnish and set them aside to be reinstalled later.

**-cont.-**

FIG. 1

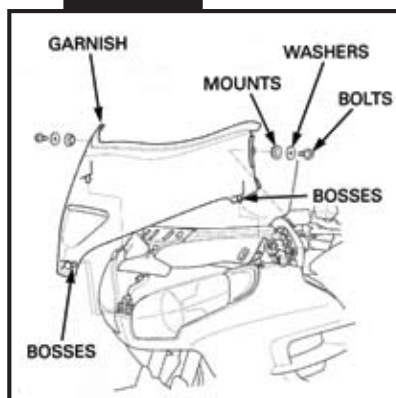

### CUSTOMER SERVICE

877.370.3604 (toll free)

### INSTALLATION QUESTIONS

techsupport@kuryakyn.com  
or call 715.247.2983

### LIMITED WARRANTY

Küryakyn warrants that any Küryakyn products sold hereunder, shall be free of defects in materials and workmanship for a period of one (1) year from the date of purchase by the consumer excepting the following provisions:

- Küryakyn shall have no obligation in the event the customer is unable to provide a receipt showing the date the customer purchased the product(s).
- The product must be properly installed, maintained and operated under normal conditions.
- Küryakyn makes no warranty, expressed or implied, with respect to any gold plated products.
- Küryakyn shall not be liable for any consequential and incidental damages, including labor and paint, resulting from failure of a Küryakyn product, failure to deliver, delay in delivery, delivery in nonconforming condition, or for any breach of contract or duty between Küryakyn and a customer.
- Küryakyn products are often intended for use in specific applications. Küryakyn makes no warranty if a Küryakyn product is used in applications other than intended.
- Küryakyn electrical products are warranted for one (1) year from the date of purchase by the consumer. Components of Küryakyn products containing L.E.D.s will be warranted for defects in materials and workmanship for 3 years from the date of purchase.
- Küryakyn makes no warranty of any kind in regard to other manufacturer's products distributed by Küryakyn. Küryakyn will pass on all warranties made by the manufacturer and where possible, will expedite the claim on behalf of the customer, but ultimately, responsibility for disposition of the warranty claim lies with the manufacturer.

### ABOUT OUR CATALOG

You'll find all our innovations for H-D, GL and Metric Cruisers in our annual catalogs. Order online today—select the "CATALOGS" icon. Each Küryakyn® product comes with a Proof-of-Purchase good for a complimentary catalog. Details in packaging.

Be sure to ask your local dealer about other Küryakyn® products, the motorcycle parts and accessories designed for riders by riders.

©2005 Küryakyn USA® All Rights reserved.



kuryakyn.com

**STEP 4** Flip the windshield height adjustment levers to the up position.

**STEP 5** Carefully pull up on the windshield garnish at the points where the bosses are located as shown in FIG. 1 to remove the garnish from the motorcycle.

**STEP 6** Remove the screw that secures the plastic trim piece as shown in PIC. 1, this trim and screw will be reinstalled.

**STEP 7** Remove the two nuts and screw that secure the windshield holding plate as shown in PIC. 2, then remove the plate; the hardware will be used again.

**STEP 8** Remove the screws, washers and plates as well as the setting screws that secure the windshield (see FIG. 2), then remove the windshield from the motorcycle; the hardware will be used to install the new windshield.

**STEP 9** Remove the hardware that secures the front grill and the inner visor together (See PIC. 3). There may be slight variations in vent styles from motorcycle to motorcycle.

**NOTE:** The vent will be reinstalled in the reverse order that it was removed.

**STEP 10** Carefully remove the inner visor from the windshield, be careful not to break the tab from the grill when removing the visor.

**STEP 11** Remove the grill from the windshield.

**STEP 12** Place the grill in the new windshield.

**STEP 13** Referring to FIG. 3, make sure that the grommets are placed between the grill and the visor; install the visor with the tab from the grill in the hole in the visor.

**STEP 14** Secure the visor and grill together with the hardware that was removed in STEP 9, refer to FIG. 3 and/or PIC. 3.

**STEP 15** Place the two center setting bolts (FIG. 2) through the two holes in the new windshield, place a washer from the hardware kit over the protruding ends of the screws and using a small piece of tape, tape the washers to the backside of the windshield to hold them in place during installation.

**STEP 16** Place the windshield on the motorcycle and start the two setting bolts.

**STEP 17** Place the plates in the correct slots in the windshield, and secure using the screws and washers that were removed in STEP 8; see FIG. 2.

**STEP 18** Reinstall the windshield holding plate, screw and nuts that were removed in STEP 7 (see PIC. 2); make sure that the tabs on the sides of the plate rest on top of the fairing stay as shown in PIC. 4.

**STEP 19** Cut the adhesive foam strip in half; clean the holding plate and install a foam pad on the upper corners of the plate as shown in PIC. 5, wrapping it from the inside of the plate to the outside.

**STEP 20** Reinstall the plastic trim piece and screw that were removed in STEP 5 (PIC. 1).

**STEP 21** Flip the windshield height adjustment levers to the down position.

-cont.-

**Kuryakyn**<sup>®</sup>

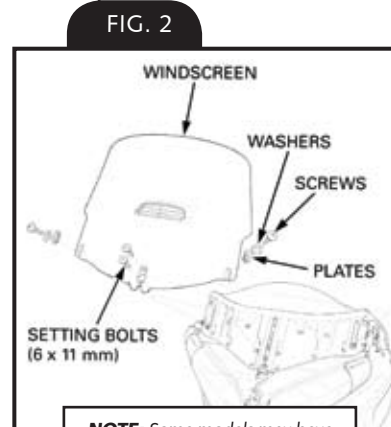
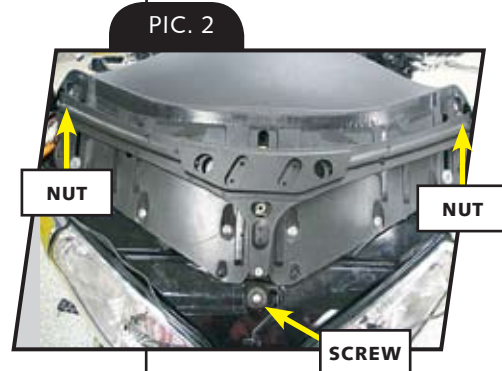
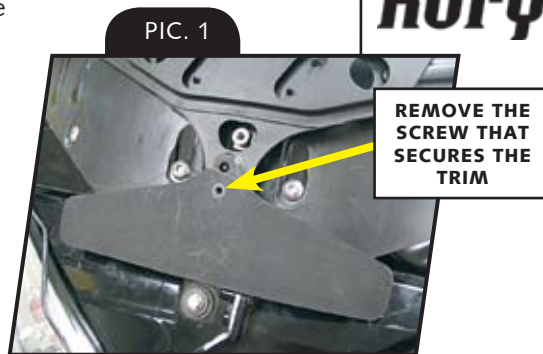

**NOTE:** Some models may have additional screws, washers and plates securing the windscreen.

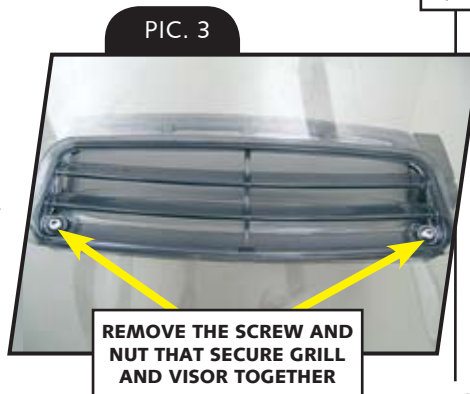

PAGE  
**2**

**STEP 22** Reinstall the fairing garnish and screws that were removed in STEPS 3 & 4.

**ATTENTION!** It is the installer's responsibility to ensure that all of the fasteners (including pre-assembled) are tightened before operation of the motorcycle. Kuryakyn will not warranty components lost due to improper installation. Periodic maintenance may be required.

**CAUTION!** Clean only with warm water and a mild, non-abrasive soap. Some cleaning products contain harsh chemicals that can severely damage product and void warranty.

**WARNING!** DO NOT CLEAN IN HOT SUN OR HIGH TEMPERATURE. POWDERED, ABRASIVE OR ALKALINE CLEANSER WILL DAMAGE THE WINDSHIELD. NEVER SCRAPE THE WINDSHIELD WITH A RAZOR BLADE OR OTHER SHARP INSTRUMENT.

**WARNING!** DO NOT USE BENZENE, PAINT THINNER, GASOLINE OR ANY OTHER TYPE OF HARSH CLEANER ON THE WINDSHIELD. DO NOT USE AMMONIA BASED SOLVENTS OR PETROLEUM DISTILLATES. DOING SO WILL DAMAGE THE WINDSHIELD SURFACE.

**WARNING!** DO NOT USE HARSH CHEMICALS INCLUDING RAIN SHEETING PRODUCTS ON MOTORCYCLE WINDSHIELDS. THEY CAN CAUSE A DULLING OR HAZING. TO OBTAIN A PROPER HIGH-END POLISH, PLEASE USE A QUALITY PROTECTOR AND POLISH SUCH AS PLEXUS® OR NOVUS® BRAND CLEANERS. DO NOT USE RAIN-X OR OTHER AMMONIA BASED CLEANING OR PROTECTION PRODUCTS.

**CAUTION!** Sunlight reflections off the inside curvature of the windshield can, at certain times of the day, cause extreme heat build-up on motorcycle instruments. Exercise care in parking. Park facing the sun, place an opaque object over the instruments, or adjust the windshield to avoid reflections.

*Ride On!*

