



SMALL HALOGEN SILVER BULLET

2336

Small Lights with Short Strut Mounts

FITS: SOFTAIL AND DYNA MODELS ('96-UP)

PART#	INCLUDED
602303	2 Small Halogen Silver Bullets with Red, Amber and Clear Lenses (Light Bodies Tapped 5/16"-18, Wire Exits Through Light Body, Visorless Bezels)
402394	2 Short Strut Mounts
200740	2 5/16"-18 x 2-1/4" Hex Bolts — Fully Threaded
200741	2 3/8"-16 x 1.138" Long Hex Bolts — Hollow (Softail only)
200217	4 3/8" I.D. Flat Washers (Softail only)
200742	2 3/8"-16 x .340 Thick Nylock Nuts (Softail only)
200743	2 Anti-Rotation Pins (Dyna only)
200509	2 5/16"-18 x 1" B.H.C.S. — Stainless
302336	1 Instruction Sheet

NOTE

These single function halogen lights may be wired for running lights OR turn signal use. For multi-function use, a Run-Turn-Brake Controller Kuryakyn P/N 4860 or 4861 (sold separately) must be used.

PROCEDURE AVERAGE TIME: 45 MINUTES

STEP 1 Remove the stock turn signals and mounts from the fender struts. Disconnect or cut the stock wires at a location that permits easy, clean, and out of the way splices. (Keep in mind the movement of the rear wheel as the suspension cycles.)

STEP 2 See FIG.1 for Softails, and FIG.2 for Dyna Models on the following page. The line drawings show how the respective anti-rotation devices are installed.

STEP 3 Softail models, insert the hollow bolt from inside the fender, with the flat washers and nylock nut placed exactly as in the drawing. The small amount that the hollow bolt protrudes through the fender strut keeps the mount from rotating.

STEP 4 PIC.1 shows the components and assembly order for Softails, and PIC.2 shows the same for Dyna models. Install the appropriate assembly on your motorcycle. Securely tighten the mounting bolt. 2000-up Softail Models: The silver bullet and mount will attach to the chrome fender strut cover only with the 5/16"-18 x 1" Button Head Cap Screw (B.H.C.S.) provided, rather than using the 2-1/4" bolt pictured.

-cont.-

PIC.1

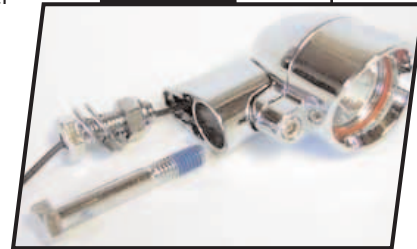

PIC.2

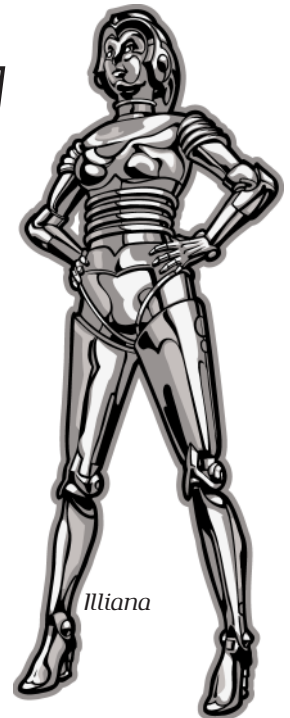

Illiana

E-MAIL

techsupport@kuryakyn.com
or call 715.247.2983

WARRANTY

Kuryakyn™ warrants that any Kuryakyn product sold hereunder, if properly installed, maintained and operated under normal conditions, shall be free from any defects in materials and workmanship for a period of one (1) year from the date the Kuryakyn products are sold to the customer.

CONSEQUENTIAL DAMAGES:
Kuryakyn shall not be liable for any consequential or incidental damages.

ABOUT OUR CATALOG

You'll find all our innovations for H-D, GL and Metric Cruisers in our annual catalogs. Order online today—select the "CATALOGS" icon. Each Kuryakyn™ product comes with a Proof-of-Purchase good for a complimentary catalog. Details in packaging.

Be sure to ask your local dealer about other Kuryakyn products, the motorcycle parts and accessories designed for riders by riders.

©2003 Kuryakyn USA™ All Rights reserved.

PROCEDURE FOR WIRING

The light is grounded by its connection to the chassis. Connect the single power wire to the bikes violet wire (right) and brown wire (left). For multi function, use the Küryakyn Run-Turn-Brake Controller for your specific application (sold separately). Do not install load equalizers on halogen models used as turn signals only!!

NOTE We do not recommend wiring Halogen Sliver Bullets with red lenses directly as running lights. Excessive heat is likely to cause lens breakage.

Ride On!

FIG.1

No.2336-37 Anti Rotation Assembly for Softail

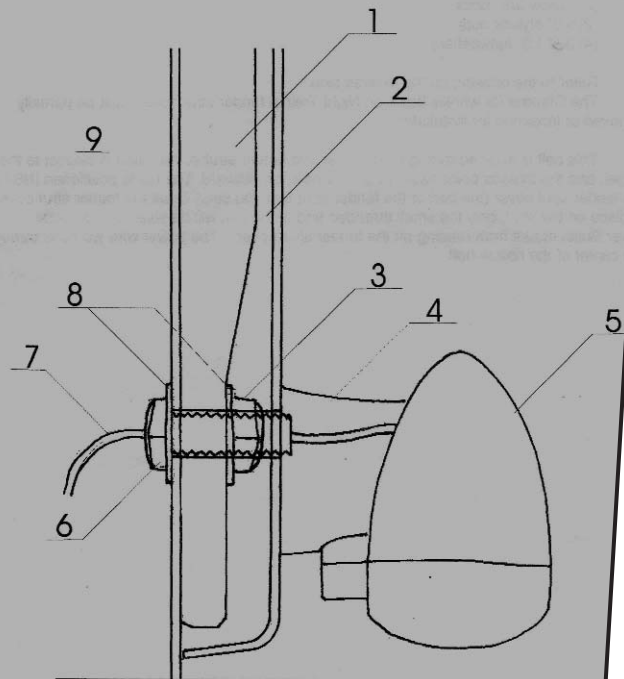

- 1. Fender Strut. 2. Strut Cover. 3. Nyloc Nut.
- 4. Bullet Mount 5. Bullet Light. 6. Hollow Bolt.
- 7. Power Wire. 8. Washers. 9. Fender.

FIG.2

No.2336-37 Anti Rotation Assembly for Dynal

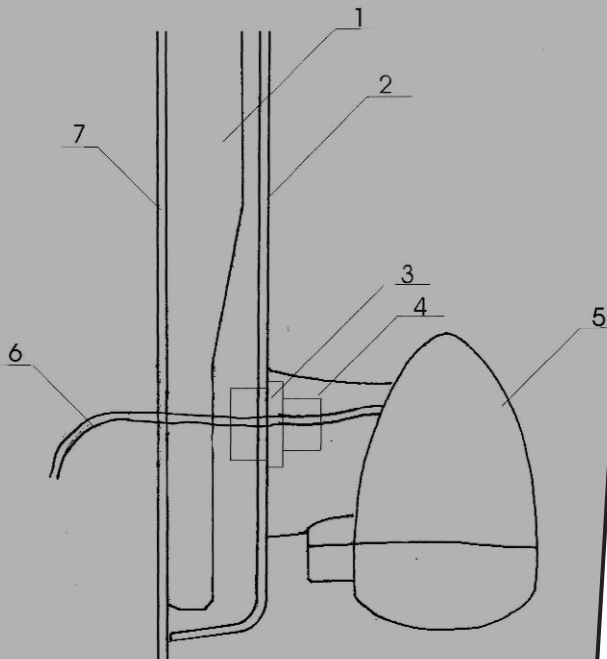

- 1. Fender Strut. 2. Strut Cover. 3. Dyna Spacer.
- 4. Bullet Mount 5. Bullet Light. 6. Power Wire.
- 7. Fender.

PAGE

2