



# INSTALLATION

## TRIPLE WHAMMY RUN-TURN-BRAKE LIGHT KIT 4605

### FOR HONDA

FITS '06-UP VTX1800R, S, T & C.

#### PARTS INCLUDED

- 1 Control Module
- 1 Flash Tab
- 1 Load Equalizer
- 2 Male Electrical Connectors
- 2 Female Electrical Connectors
- 1 Dielectric Grease
- 4 Cable Ties
- 2 PR21W Red Bulbs
- 1 Installation Instructions

Please read and understand entire instructions before starting installation.

#### THANK YOU FOR CHOOSING KÜRYAKYN!

#### TOOLS SUGGESTED

Test light

#### IMPORTANT INFORMATION! PLEASE READ BEFORE STARTING INSTALLATION.

- The control module is compatible with motorcycles that have the rear lighting circuit wiring in stock configuration. If the motorcycle is already equipped with a Honda accessory control module or other aftermarket control module, remove it before installing the Run-Turn-Brake control module.
- The control module is compatible with stock rear single-circuit turn signals, as well as custom single-circuit lights and LEDs. Any existing load equalizers must be removed prior to installing the Run-Turn-Brake control module. Any load equalizers necessary after installation of the Run-Turn-Brake control module can be reinstalled later. NEVER install a load equalizer between the control module and the rear lights!
- The control module adds "Run", "Turn", and "Brake" function to stock rear single-circuit turn signals, as well as custom single-circuit lights and LEDs.

**ATTENTION!** The rear turn signals must be fit with the included red bulbs to meet State and Federal Regulations. Check with your local laws before re-using stock amber lenses or bulbs on any lights on the rear of the motorcycle.

**ATTENTION!** A factory service manual may be helpful in performing this installation. Do not attempt to perform this installation if you are not confident in your ability to complete all steps in the procedure; consult a trained technician.

-cont.-

#### CUSTOMER SERVICE

877.370.3604 (toll free)

#### INSTALLATION QUESTIONS

techsupport@kuryakyn.com  
or call 715.247.2983

#### LIMITED WARRANTY

Kuryakyn warrants that any Kuryakyn products sold hereunder, shall be free of defects in materials and workmanship for a period of one (1) year from the date of purchase by the consumer excepting the following provisions:

- Kuryakyn shall have no obligation in the event the customer is unable to provide a receipt showing the date the customer purchased the product(s).
- The product must be properly installed, maintained and operated under normal conditions.
- Kuryakyn makes no warranty, expressed or implied, with respect to any gold plated products.
- Kuryakyn shall not be liable for any consequential and incidental damages, including labor and paint, resulting from failure of a Kuryakyn product, failure to deliver, delay in delivery, delivery in nonconforming condition, or for any breach of contract or duty between Kuryakyn and a customer.
- Kuryakyn products are often intended for use in specific applications. Kuryakyn makes no warranty if a Kuryakyn product is used in applications other than intended.
- Kuryakyn electrical products are warranted for one (1) year from the date of purchase by the consumer. Components of Kuryakyn products containing L.E.D.s will be warranted for defects in materials and workmanship for 3 years from the date of purchase.
- Kuryakyn makes no warranty of any kind in regard to other manufacturer's products distributed by Kuryakyn. Kuryakyn will pass on all warranties made by the manufacturer and where possible, will expedite the claim on behalf of the customer, but ultimately, responsibility for disposition of the warranty claim lies with the manufacturer.

#### ABOUT OUR CATALOG

You'll find all our innovations for H-D, GL and Metric Cruisers in our annual catalogs. Order online today—select the "CATALOGS" icon. Each Kuryakyn product comes with a Proof-of-Purchase good for a complimentary catalog. Details in packaging.

Be sure to ask your local dealer about other Kuryakyn products, the motorcycle parts and accessories designed for riders by riders.

©2005 Kuryakyn USA All Rights reserved.



## PROCEDURE

**STEP 1** Locate the rear fender wiring harness behind the right side cover. See [PIC.1](#). To remove the right side cover, pull the rear corner out, then gently pull the cover towards the front of the bike.

**STEP 2** Lift the locking tab on the wiring harness tie strap and remove the tie strap; save for reuse. See [PIC.2](#). Slide the rubber boot back to expose the stock wiring connections. See [PIC.3](#).

**CAUTION!** Pay close attention to the following procedure; Kuryakyn will NOT warranty control modules that have been improperly installed. If you are unsure about the procedure, contact a qualified technician.

**CAUTION!** While performing this procedure, be sure not to direct ground any of the power wires or you may blow the fuse.

**STEP 3** Identify and mark your stock connectors: See [PIC.3](#). Turn the ignition "on" then turn on the right blinker. Disconnect then reconnect each connector plug, watching for the blinker to go out. Mark the right blinker connector plug. Repeat the procedure for the left blinker, then the taillight, marking each connector plug.

**STEP 4** Determine the wire functions on your stock connectors: Use a test light or your factory service manual to identify the wire functions in each of the stock connectors. Mark the wires in both halves of each connector then separate the halves of each connector.

**STEP 5** Assemble the empty individual connectors: You must assemble the control module connectors to mate correctly with your stock connectors. Test fit the supplied empty connector plugs to the mating connector plugs on the bike to identify the correct orientation of the connectors. Mark the connector so that you will know which side if the empty connector is the "hot" side. See [PIC.4](#).

**ATTENTION!** Be very careful when installing the terminal pins into the connectors—they cannot be easily removed. Pay close attention to the orientation of the pins in the connectors; refer to [PIC.4](#).

**ATTENTION!** Double-check all of your connections! Incorrect connections could damage the control module. Kuryakyn will NOT warranty parts damaged due to improper installation.

**STEP 6** Carefully separate the empty connector half from the stock connector. Insert the correct wires from the control module into the connector plug, verifying the correct orientation of the terminal end. Be sure the wire functions on the control module match the wire functions on the stock connector. See [PIC.5](#). The terminals will lock once they are seated.

**STEP 7** Plug the mating halves of the control module connectors into the mating half of the stock connectors. Be sure to put a dab of dielectric grease on the terminals before connecting the plugs.

-cont.-

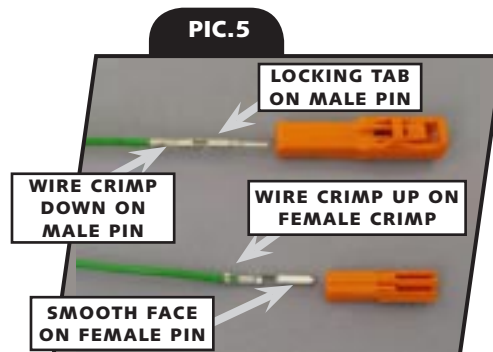

# Kuryakyn

**PIC.1**



**PIC.2**



**PIC.3**

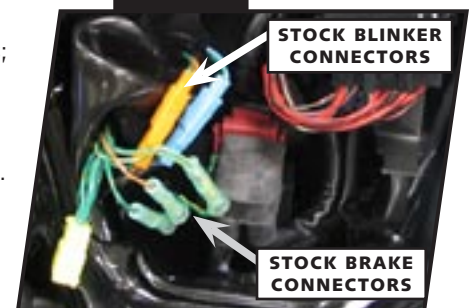

**PIC.4**



PAGE  
**2**

**TRIPLE WHAMMY INSTALLATION**

**STEP 8** Plug the mating halves of the control module bullet connectors into the mating halves of the stock bullet connectors. See [PIC.6](#) and [PIC.7](#). Be sure the clear plastic sleeves cover all the metal of the connections once the ends are joined.

**STEP 9** Remove the screw on the underside of the rear turn signal; gently lift up and out on the lens assembly to remove it. Do not lose the threaded clip on the bottom of the lens.

**STEP 10** Push the bulb into the socket and turn counter-clockwise to remove; lift bulb out of the socket.

**STEP 11** Insert the new bulb into the socket.

**STEP 12** Push the bulb straight into the socket and turn clockwise to secure. PR21W Red bulbs have indexing pins on their base. They can only be installed one way.

**STEP 13** Remove the threaded clip from the stock rear turn signal lens and install it on the new lens. Reinstall the lens on the bike with the screw removed in STEP 9.

**NOTE** The control module is supplied with a flash tab. See [PIC.8](#). With the flash tab installed, the brake light will flash momentarily, then illuminate steady when the brake is applied. With the flash tab removed, the brake light illuminates steady when the brake is applied. Be sure the ignition is "off" before installing or removing the flash tab.

**STEP 14** Start the motorcycle and test the function of the control module:

- A)** Verify the tail lamp and turn signals illuminate in "run" mode.
- B)** Apply the brake; if the flash tab is installed, verify the brake light flashes briefly before illuminating steady. If the flash tab is not installed, verify the brake light illuminates steady while the brake is activated.
- C)** Verify the turn signals operate correctly, in both "run" mode and with the brake applied. If the turn signals flash too rapidly or operate erratically, you will need to install a load equalizer. See the end of this document for the load equalizer installation procedure.

**STEP 15** Slide the rubber boot back over the connections and secure the boot and the control module to the frame with the tie strap. Be sure the components do not come in contact with any moving parts or interfere with the proper operation of the motorcycle.

**STEP 16** Re-install the cover, unless you are installing the load equalizer.  
Installing the Load Equalizer

**ATTENTION!** Any load equalizers must be installed upstream of the control module. NEVER install a load equalizer between the control module and the rear lights.

**STEP 17** The motorcycle must be off before installing the load equalizer. Plug the load equalizer into an empty 3-pin socket on the control module. See [PIC.9](#).

**STEP 18** Start the motorcycle and retest the light functions, refer to STEP 15. If the lights still flash too rapidly or operate erratically, you will need to install a second load equalizer (Küryakyn P/N 4810, sold separately).

-cont-

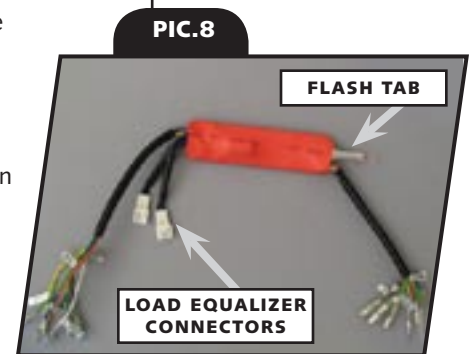
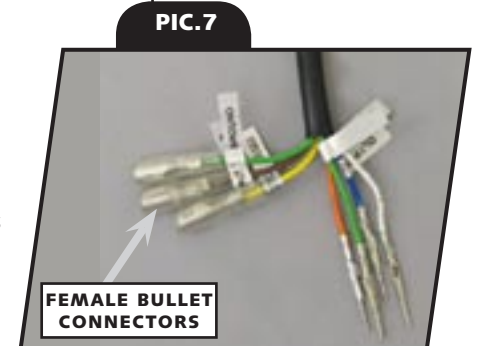
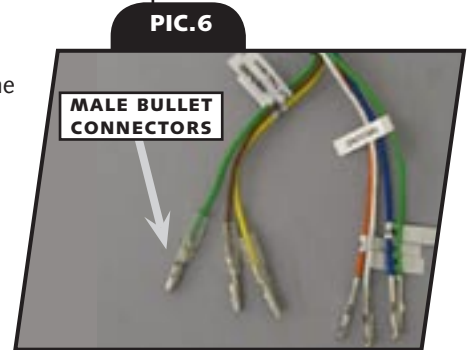

PAGE

**3**

**STEP 19** The load equalizers become warm during normal operation of the turn signals. Secure the load equalizer to the motorcycle frame; this will act as a heat sink and help cool the load equalizer. Keep the load equalizer away from any heat-sensitive components.

**STEP 20** Re-install the side cover.

**WARNING!** DO NOT SECURE THE LOAD EQUALIZER TO THE CONTROL MODULE! EXCESS HEAT FROM THE LOAD EQUALIZER COULD DAMAGE THE CONTROL MODULE.

**WARNING!** ALWAYS INSTALL THE LOAD EQUALIZER UPSTREAM OF ANY EXISTING AFTERMARKET MULTIFUNCTION CONTROL MODULES. DO NOT INSTALL A LOAD EQUALIZER BETWEEN A MODULE AND THE TURN SIGNALS AS THIS WILL OVERLOAD THE MODULE. OVERLOADING WILL DAMAGE THE MODULE AND CREATE A FIRE HAZARD!

**WARNING!** LOAD EQUALIZERS GENERATE HEAT WHEN IN USE. AVOID USING THE TURN SIGNALS FOR AN EXTENDED PERIOD OF TIME, OTHERWISE THE LOAD EQUALIZER WILL OVERHEAT. NEVER OPERATE THE FOUR-WAY FLASHERS UNLESS YOU FIRST REMOVE THE LOAD EQUALIZER. OVERHEATING WILL DAMAGE THE LOAD EQUALIZER, CAUSING LOSS OF TURN SIGNAL OPERATION AND CREATES A FIRE HAZARD!

*Ride On!*

**Kuryakyn**

**PAGE**

**4**

**TRIPLE WHAMMY** **INSTALLATION**